

PRIMEROYAL[®]

Series Metering Pumps



The Force in Pump Technology

PRIMEROYAL® Series Metering Pumps

A history of reliability

With over 80 years of experience, Milton Roy combines vast industry experience, a proven track record, and a culture of continuous technological improvement to provide customized solutions for all pump applications.

Milton Roy delivers the market's most reliable, comprehensive range of metering pumps. All our pumps are engineered to exceed expectations and is backed by a global network of highly trained field engineers and after-sales support that is second-to-none.

Unsurpassed reliability and versatility in critical chemical dosing applications

The outstanding reliability of PRIMEROYAL® series pumps begins with a robust gear mechanism and a modular design. These highly flexible pumps accept several types of liquid ends and capacity-control options for the specific requirements of your application. More than a half-century of experience combines with advanced pump-engineering technologies to give you continuous operation with the longest possible time between scheduled maintenance.

The combination of robust, field-proven design and flexible modularity makes PRIMEROYAL® pumps suitable for a large number of industrial processes. The PRIMEROYAL® range provides accurate dosing of a broad spectrum of fluids at flow rates that can reach maximum 49,470 l/h (13,068 gph) in the triplex configuration.

With its versatile, modular design and wide range of options, PRIMEROYAL® pumps can be precisely configured for your applications.

Flexible Design

With its versatile, modular design and wide range of equipment and material options, PRIMEROYAL® pumps are an integrated pump system that can be precisely configured for your applications.

- Six frame sizes with a wide flow rate and pressure range
- Selection of liquid-end types and operation option
- Multiplexing available in any combination of frame sizes
- Variable or fixed stroke length
- Adjustable flow manually or automatically while running or stopped



The PRIMEROYAL X with metallic liquid end and PTFE (Teflon®) double diaphragm, horizontal motor configuration, and actuator with integrated electronic controls.







PLG pump – GSD liquid end



PRIMEROYAL R Triplex Configuration

PRIMERROY® and PRIMERROYAL® Range

Selection chart

Liquid End		Packed Plunger				Metallic Diaphragm				PTFE Diaphragm					
		P4 (NX)		P2 - P3 (UT or N)		M2 (MX)		M1 (M)		H5 (HX)		H1 - H2 - H3 - H4 (HPD)		G1 - G2 (GSD)	
Pumps		Max. Flow l/h (gph)	Max. Pressure bar (psi)	Max. Flow l/h (gph)	Max. Pressure bar (psi)	Max. Flow l/h (gph)	Max. Pressure bar (psi)	Max. Flow l/h (gph)	Max. Pressure bar (psi)	Max. Flow l/h (gph)	Max. Pressure bar (psi)	Max. Flow l/h (gph)	Max. Pressure bar (psi)	Max. Flow l/h (gph)	Max. Pressure bar (psi)
	PK	38 (10)	930 (13,488)	2,062 (544)	300 (4,351)			195 (51)	500 (7,251)			330 (87)	151 (2,190)		
	PKG													2,500 (660)	37 (536)
	PL	87 (22)	1,000 (14,503)	3,480 (919)	309 (4,481)	66 (17)	1,034 (14,996)	242 (63)	500 (7,251)			4,410 (1,164)	286 (4,148)		
	PLG													3,300 (871)	45 (652)
	PN	265 (70)	1,000 (14,503)	9,863 (2,605)	244 (3,538)	363 (95)	1,034 (14,996)	230 (60)	500 (7,251)	1,958 (517)	248 (3,596)	8,649 (2,284)	300 (4,351)		
	PP			15,665 (4,138)	306 (4,438)					8,284 (2,188)	310 (4,496)	10,056 (2,656)	93 (1,348)		
	PR	793 (209)	1,000 (14,503)	15,659 (4,136)	319 (4,626)	793 (209)	1,034 (14,996)			8,284 (2,188)	397 (5,758)	12,549 (3,315)	25 (362)		
	PX	1,268 (334)	980 (14,213)			1,980 (523)	1,029 (14,924)			16,490 (4,356)	252 (3,654)				

General Specifications

- Flow rate: from 0.2 l/h (0.05 gph) to 16.5 m³/h (4,358 gph) in simplex configuration
- Pressure: up to 1,034 bar (15,000 psi) in standard
- Multiplexable
- Accuracy: ±1%, even for low flow rates and high pressures
- Fluid temperature: from -30°C to 150°C (-22°F to 302°F)
- Ambient operating temperature: from -40°C to 50°C (-40°F to 122°F)
- Stroke adjustment: from 0 to 100% of nominal flow rate
- Explosion-proof version: complying with ATEX CE EX II 2 G/D c T3 or T4 upon request
- Standard liquid-end materials include: 316L, PVC, 17-4PH, and Alloy 20

Milton Roy and our trusted partners can help to:

- Guide you in selecting the turnkey solution that best suits your needs
- Advise you on the optimum installation of your equipment
- Propose a wide range of accessories to complete the installation of your pump
- Advise you on the essential wear parts to be kept on hand in order to optimize the performance of your equipment
- Provide turnkey dosing solutions, from a skid-mounted pump to a complex, 100% customized chemical injection package

Applications

PRIMERROYAL® metering pumps are preferred in a wide range of industries:

- **Utilities:**

- Conditioning of make-up water, protection of boilers, cooling systems and hydraulic systems (biocides, antifoam, oxygen scavengers, scale inhibitors, etc.)

- **Chemistry/Petrochemistry:**

- Injection of additives and injection of sulphuric acid into water, transfer of ammonia water
- ETO charge pump, dosing ENB (Ethylidene Norbornene), injection of additives and reactants, transfer of condensate before treatment
- Dosing catalyst for polymerization of polyethylene and polypropylene,

- **Refinery/Downstream:**

- Injection of boiler feedwater and anti-fouling, transfer of sour water before treatment, injection of catalyst
- Injection of DMDS (dimethyl disulfide), boiler feed water pump, metering of additives
- Injection of chemicals, injection of paraffine inhibitor into fuel storage tanks

- **Oil & Gas:**

- Upstream: injection of methanol, monoethylene glycol, corrosion inhibitors and many more to prevent hydrate formation, wax and scale deposits and corrosion in deepwater wells
- Midstream: injection of corrosion inhibitors for produced oil and gas integrity during transportation
- Downstream: injection of chemicals for separation and treatment of refined products to control the oil viscosity, treatment of produced water (transfer, injection of coagulants...)
- Produced water treatment: injection of sodium hypochlorite, biocides, scale inhibitors, oxygen reducing agent, demulsifier, reverse emulsion breakers etc.

- **Mining:**

- Injection of reagents to wash extracting ores such as platinum or gold

- **Food and beverage industry:**

- Cleaning in place
- Injection of enzymes and caustic soda in refining and distilling applications

- **Power generation:**

- Metering of biocide, hypochlorite to prevent fouling of the mechanical equipment and pipework
- High-pressure boiler feed water treatment

- **Refinery/Petrochemistry/Chemistry:**

- Pumping of hydrocarbons/LP steam condensate, transfer of ammonia water in fertilizer plant, manufacturing of DME (dimethyl ether) from methanol

- **General industry:**

- High pressure cleaning of mechanical parts for industry

- **Municipal drinking/wastewater plants:**

- Coagulation/flocculation (injection of ferric chloride, aluminium sulphate, etc.), pH regulation (injection of acids and alkalis), water conditioning before and/or after RO treatment in desalination plant

- **Industrial water treatment:**

- Protection of installation such as boilers and hydraulic systems (corrosion inhibitors, biocides, scale inhibitors, amines, etc.)

Features and Benefits

Why PRIMEROYAL® pumps are your best choice

Reliability, Precise Control

Innovations such as the variable eccentric drive combine with proven experience in metering pump technology to give you the highest reliability in the most critical applications while performing with high repeatable accuracy.

- Built to API 675 standards
- Maximum performance in a small footprint
- Diaphragm liquid ends guaranteed leakproof with service life in excess of 20,000 hours
- Field-proven operation under low temperatures or offshore applications
- Can pump a wide range of chemicals including acids, bases, corrosive or viscous liquids, and slurries

Triplex PRIMEROYAL® Pumps

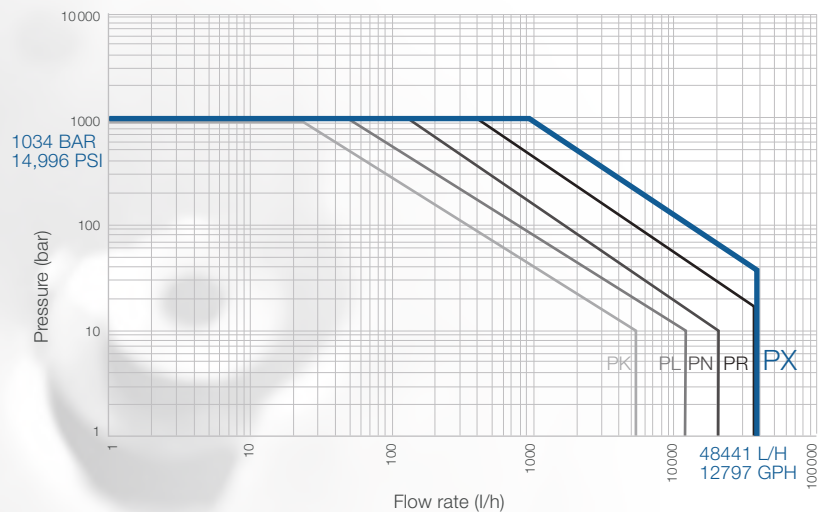

Compact and Durable Variable Eccentric Drive

In critical processes, the PRIMEROYAL® variable eccentric drive assures compactness, durability and optimum performance for the entire chemical dosing system.

This innovation is a no-lost-motion design compared to designs that have stop plates or rods to limit the plunger travel. Lost-motion designs also rely on spring return mechanisms to keep the plunger in contact with the eccentric.

PRIMEROYAL® pumps power the full stroke cycle, which eliminates the mechanical and hydraulic shocks inherent in lost-motion drives.

The PRIMEROYAL® variable eccentric drive enables precise control of the pump delivery rate while meeting or exceeding industry standards for steady-state accuracy and repeatability.

PRIMEROYAL® pumps achieve this high level of performance in a compact size, for the greatest installation flexibility.

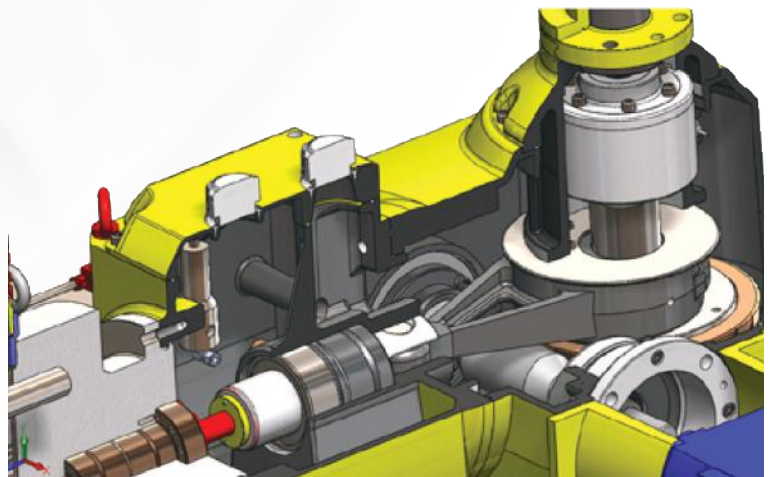

Liquid Ends

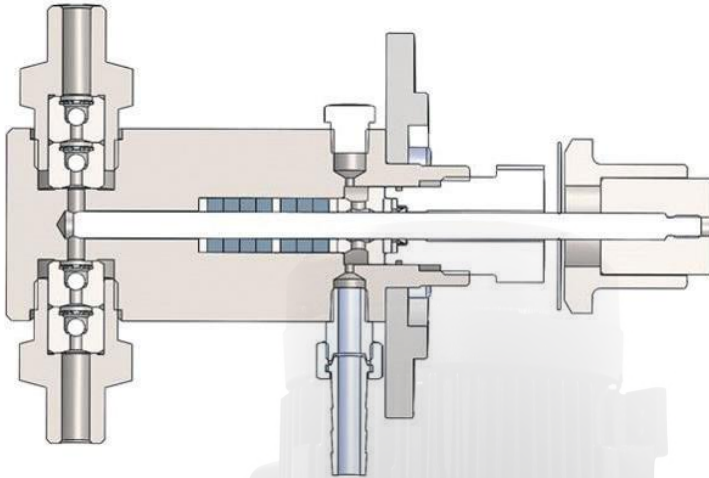

Packed Plunger Liquid Ends

The packed plunger liquid end offers the best performance when net-positive inlet pressure is an issue. The plunger is in direct contact with the process fluid, to provide the most efficient pumping performance:

- Ideal for viscous fluids and low NPSHa
- Options available to high temperatures
- Pressures up to 1,000 bar (14,504 psi)
- Standard plungers provide long plunger life in excess of 20,000 hours
- Model P4 (NX) assures leak-free operation

Metallic Double Diaphragm Liquid Ends

Milton Roy's metallic diaphragm liquid end easily handles the most severe high-pressure, high-flow applications:

- High pressure applications up to 1,034 bar (14,996 psi)
- Hydraulically balanced diaphragm minimizes stress
- Standard diaphragm material is 301 or 316L stainless steel. Modified materials are available to suit the process fluid
- Dosing of specific products such as radioactive or diffusing liquids
- Internal safety valve: patented, differential pressure valve with integrated air bleed. Adjustable pressure setting
- Assembly designed for service life in excess of 10,000 hours
- Oil compensation valve with adjustable pressure setting

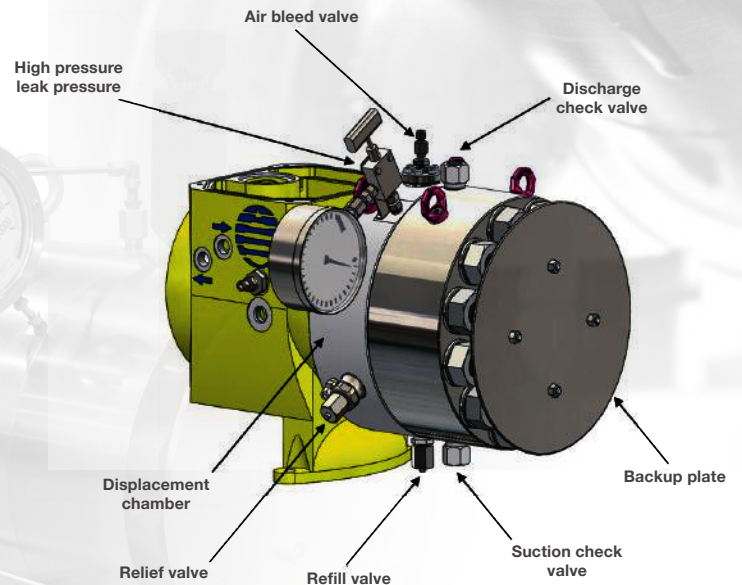

PTFE Double Diaphragm Liquid Ends

Milton Roy's proven High-Performance Diaphragm (H1 - H2 - H3 - H4 (HPD)) liquid end combines the best characteristics of traditional liquid ends with a simple and elegant design.

- Hydraulically balanced diaphragm minimizes stress and assures long diaphragm life
- Diaphragm PTFE wetted surface provides wide chemical compatibility with process fluids while composite materials (not for H5 (HX)) allow maximum flexibility
- Adjustable internal relief valve in hydraulic system protects pump from overpressure
- Patented MARS system offers a number of advantages over traditional refill systems
- 316L stainless steel or PVC version with single or double diaphragm
- Handles pressures up to 397 bar (5,758 psi) without impact on diaphragm life
- Completely leakproof
- Self-formed PTFE diaphragm or molded preformed PTFE/elastomer compound diaphragm, depending on model
- Patented reusable diaphragm. Service life in excess of 20,000 hours

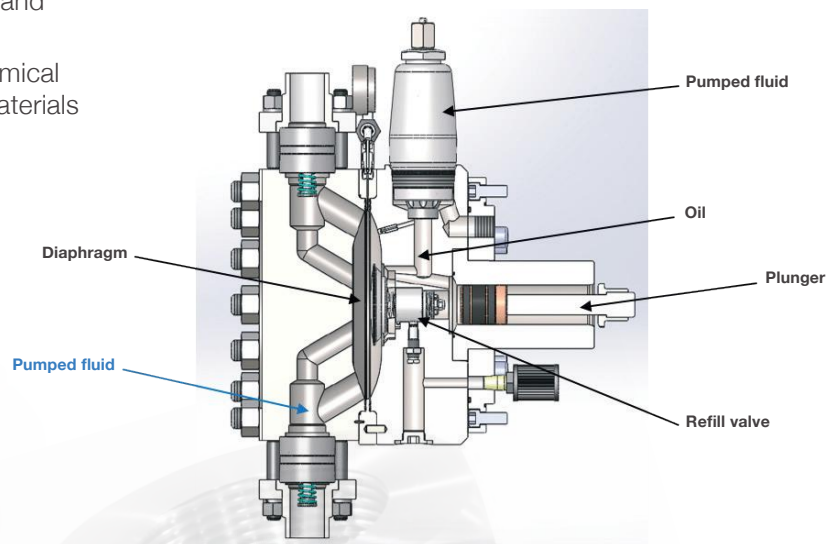

Responsive Support

Our outstanding team of highly-competent engineers, technicians, and partners can provide world-class service and support. Not only can we assist you in selecting the optimal pump to meet your requirements, but we can deliver service throughout the pump's lifecycle from installation to after-sales support.

- Project management and packaging services
- Installation and commissioning of your pump
- Manufacturer's documentation including material certifications, drawings, parts list, etc.
- Testing services such as hydrostatic, vibration, noise, X-ray, etc.
- Spare parts and repair services for preventative and critical maintenance

Design Options

The PRIMEROYAL® series offers options to meet the requirements of most applications including, but not limited to:

- Electronic capacity control by actuator
- Variable speed drive control
- Flanged, NPT, and other connections as required
- Specified liquid end materials
- Special base plates
- Diaphragm Rupture Detection system
- Steam or cooling jackets
- Remote head
- High and low temperature configurations
- NEMA and IEC flange motor mount options
- Special check valves for all types of fluid

We are a proud member of Accudyne Industries, a leading global provider of precision-engineered, process-critical and technologically advanced flow control systems and industrial compressors. Delivering consistently high levels of performance, we enable customers in the most important industries and harshest environments around the world to accomplish their missions.



To learn more about the PRIMEROYAL® series of metering pumps, contact your local representative or visit our website.

www.miltonroy.com

Americas

201 Ivyland Road
Ivyland, PA 18974, USA
Tel: (215) 441-0800
Fax: (215) 441-8620

info@miltonroy.com

Europe, Middle East, Africa

10 Grande Rue
27360 Pont-Saint-Pierre, France
Tel: +33-(0) 2-32-68-3000
Fax: +33-(0) 2-32-68-3093

mr14.contact@miltonroy.com

Asia

Plot No: P 45/1
Domestic Tariff Area 8th Avenue
Mahindra World City
Chengalpattu - 603 002, India
Tel: 91-44-2225-4000 to 3
Fax: 91-44-2225-4004

miltonroyindia@vsnl.net

510 Thompson Road
#13-01, SLF Building
Singapore 298135
Tel: 65-6568-2800

salesaccsg@miltonroy.com

Building 1, No. 879 Shen Fu Road
XinZhuang Industrial Zone
Min Hang District
Shanghai, China 201108
Tel: 8621 5055 5005
Fax: 8621 5442 5265

marketing.mris@miltonroy.com

Picture for illustration purposes only. We reserve the right to modify the characteristics of our products without prior notice

